



R610



RIBADITRICE A MOVIMENTO ORBITALE

CE n° IMQ BM156DM



MORUECO

RIBADITRICE A MOVIMENTO ORBITALE

ORBITAL RIVETING MACHINE

Caratteristiche tecniche

R610

Technical data

capacità di ribaditura R=40 kg/mm ²	mm.	Ø2÷10	mm.	riveting capacity R=40 kg/mm ²
corsa a regolazione micrometrica	mm.	0÷40	mm.	micrometric control stroke
luce minima e massima	mm.	85÷225	mm.	port min and max
piano di lavoro	mm.	270x285	mm.	work table
scanalature a "T"	mm.	10x22	mm.	"T" slots
diametro utensili	mm.	12	mm.	tool diameter
lunghezza utensile A	mm.	58	mm.	tool length A
lunghezza utensile B	mm.	100	mm.	tool length B
lunghezza utensile C	mm.	76	mm.	tool length C
tensione elettrica		400V-50Hz		line voltage
pressione di linea	bar	2÷6	bar	line pressure
pressione di lavoro	bar	1÷6	bar	working pressure
tempo di lavoro	sec.	0,1÷9,9	sec.	time control
peso totale	kg.	220	kg.	total weight

con riserve di modifiche senza preavviso - specifications are subject to change without notice

CE n°IMQ BM 156 DM

esempi di ribaditura

examples of assembling

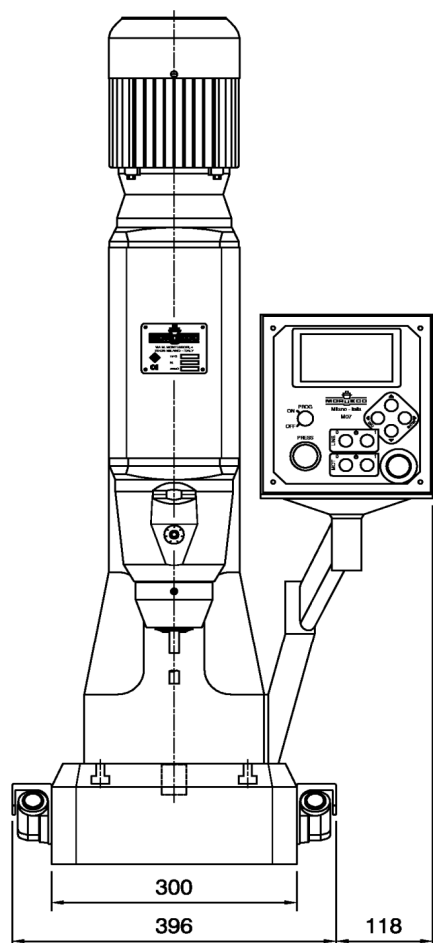
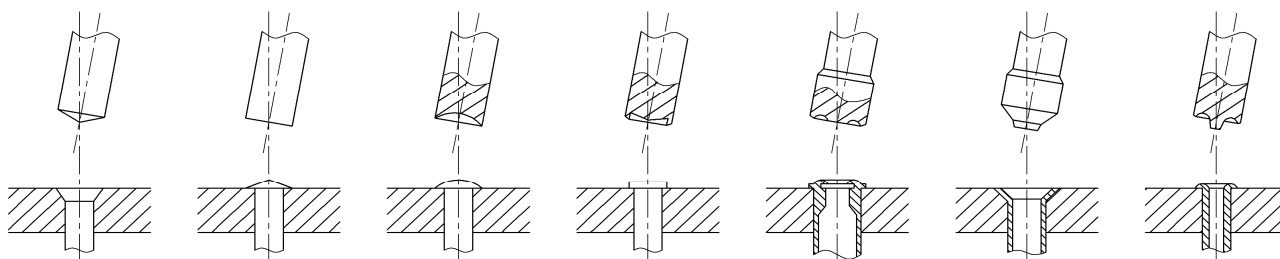

R610

